

## Intelligent Single and Double Loop Fire Alarm Panel GST200-2



### Features and Benefits

1. Listed to LPCB standard
2. 2 Loop capacity-477 Addressable Point
3. 8x18 Graphical LCD Display
4. 30 Zone indication including manual intervention and control
5. 3 programmable alarm output
6. Positive Alarm Signal (PAS) Pre-alarm
7. Maintenance report of dirty detector
8. Networkable with all GST Intelligent Fire Alarm panels
9. Programmable form PC by GSTDef2.1
10. History log 999-events capacity in non-volatile memory
11. Walk Test Facility
12. RS485 Repeater Output (Max. 10)
13. Advanced user friendly programming software including 'Fuzzy Logic'
14. Optional RS 232 Colour Graphics Software, Printer and Pager Interface
15. Optional RS485 Network Card
16. Optional Fireman's Control Panel
17. Optional Panel Printer

### Description:

The GST 200-2 single loop and two loop addressable fire detection control panel is packed with features that are not usually associated with smaller and medium systems. The GST 200-2 provides a high quality solution at exceptional value.

By utilizing advanced GST Protocol, the system is compatible with the complete range of GST intelligent detectors, Sounders, Call Points, Interfaces, including gas extinguishing control.

The GST 200-2 is manufactured and certified to EN54 parts 2 and 4 and to BS5839 Part 4. The GSTDef2.1 programming facilities enables advanced and complex cause and effects to be programmed with ease, including phased and cascade evacuation scenario. The GST zonal indication and control facility allows the operator to manually intervene, with evacuation and control of each zone, including control of all plant equipment under an alarm condition.

Maintenance report of dirty detector, pre-alarm signal and gas release controls are built in as standard, making the system ideal for many applications such as Banks, Shops, Telecommunication Centers and GSM exchanges, industrial and commercial facilities.

By utilizing the GST protocol the GST200-2 can be networked with up to 32 panels, not only the GST200 single loop panel, but also with the New GST-IFP8, GST5000 series and the GST5000 modular 20 loop controller, making this the perfect solution for large decentralized systems such as Shopping Centers Military campus industrial complexes, Holiday villages etc.



## Intelligent Single and Double Loop Fire Alarm Panel GST200-2

### Fascia and Dimension



### Board Diagram

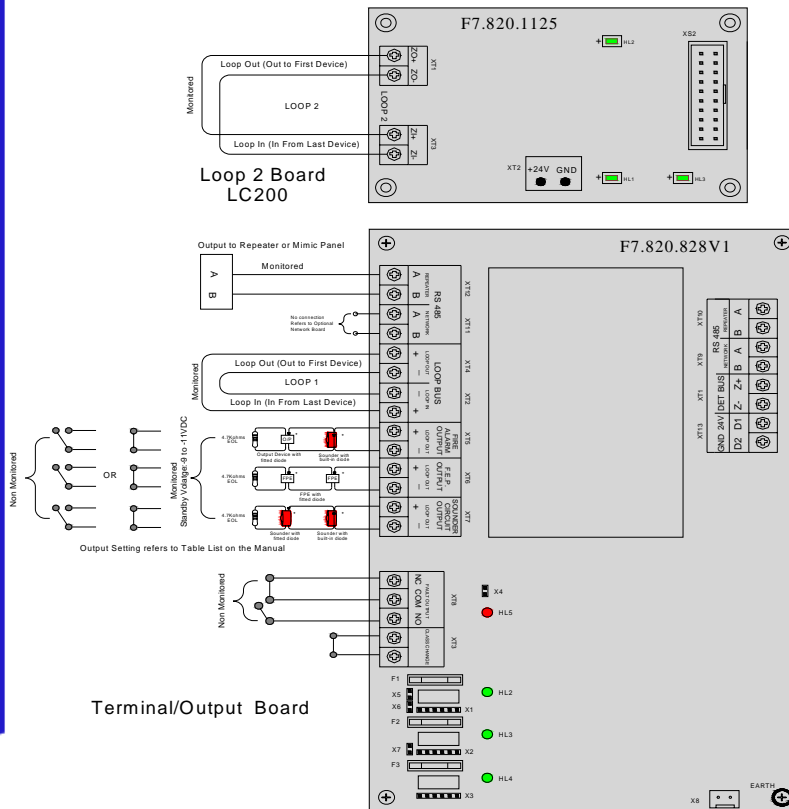

### Optional Board

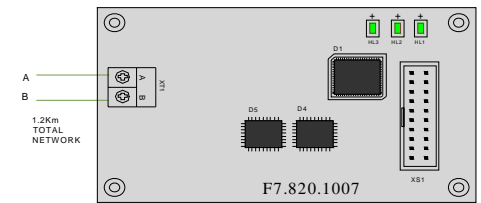
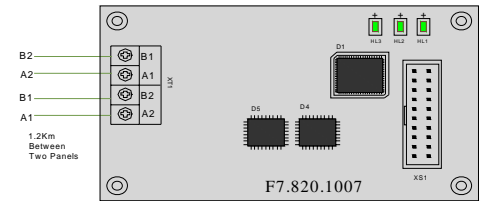
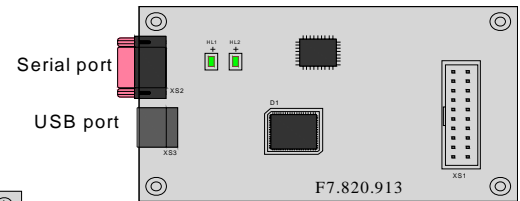

www.gst.uk.com  
info@gst.uk.com

**GST England** Lion Court, Staunton Harold Hall, Melbourne Road, Ashby de la Zouch, Leicestershire, England LE65 1RT Tel: +44 1283 225 478 Fax: +44 1283 220 690

**GST Dubai** ZA04, Jebel Ali Free Zone, P.O.Box 17998, Dubai UAE Tel: +971 (0)4 8833 050 Fax: +971 (0)4 8833 053

**GST China** 80, Changjiang East Road, Economic & Technology Development Zone Qinhuangdao, Hebei, China Tel: +86(0)335 850 2383 Fax: +86 (0)335 850 7588



www.gst.uk.com  
info@gst.uk.com



Global System Technology PLC  
*The Intelligent Solution*

## Intelligent Single and Double Loop Fire Alarm Panel GST200-2

### Technical Specification

- Standard EN54 Part 2/4 ; BS5839 Part 4
- Approvals LPCB
- Main Input Voltage 220 ± 10% VAC 50/60 Hz
- Input Current Rating 0.500A
- System Operating Voltage 24 VDC Nominal (20-27 VDC)
- Loop Capacity Loop 1: 235 ; loop 2: 242(Address)
- Loop Length 1.00mm<sup>2</sup>-800M-Full Load  
1.5mm<sup>2</sup>-1.2Km-Full Load  
2.0mm<sup>2</sup>-1.5Km-Half Load
- Loop Topology Class A or Class B
- Zone Capacity 60 Zones programmable
- Sounder Circuits (3) Fire Alarm Output: 500mA /24Vdc/NO-NC  
F.P.E. Output: 500mA /24Vdc/NO-NC  
Sounder Circuit Output: 500mA /24Vdc/NO-NC
- Fuses Mains 1A (20mm A/S ceramic)  
Sounders (2): 1A (20mm A/S)  
Fire alarm Output 0.5A (20mm A/S)  
Battery: 2A (20mm A/S HRC ceramic)  
Volt-free changeover 1.0A at 24 VDC  
Maximum load 500mA at 17-28VDC  
Twin 12 VDC Bat;24AH  
600mA  
Outer: 580 x 420 x 30 mm  
Inner: 550 x 393 x 173 mm
- Common Fault Relay Output
- 24 VDC Fused Output
- Standby Batteries
- Battery Charging Current Limit
- Dimension (HLW)

### Selection of GST200-2/N compatible addressable devices and Panels

- ✓ GST-IFP8 8Loops Intelligent Fire Alarm Controller
- ✓ GST5000W/2/4 Intelligent Fire Alarm Controller
- ✓ GST5000F/8 Intelligent Fire Alarm Controller
- ✓ GST5000R/C 1-20 Loops Intelligent Fire Alarm Controller
- ✓ GST200 Fire Alarm Panel
- ✓ GSTGMC Graphic Monitor Software
- ✓ GST-NRP01 Network Repeater Panel
- ✓ GST852RP LCD Passive Repeater Panel
- ✓ GST8903 Mimic Panel
- ✓ DI-910N Digital Intelligent Detector Series
- ✓ DI-920N Digital Manual Call Point Series
- ✓ DI-9400 Addressable Sounder Series
- ✓ I-910N Intelligent Analogue Detector Series
- ✓ I-9202 Addressable Manual Call Point Series
- ✓ I-9300 Addressable Series interfaces (Complete range for all requirements)
- ✓ I-9400 Addressable Series Sounders and strobes
- ✓ I-9600 Intelligent Series Combustible gas detectors

### Ordering Information:

Part No	Description	Pack Qty per Box
GST200-2/1	Intelligent Single Loop Fire Alarm Panel	1
GST200-2/2	Intelligent Two Loop Fire Alarm Panel	1
P-9901A	Panel Printer	1
P-9930	Compatible with USB and Serial Port, RS 232 Communication Board for System Commissioning and GMC connection	1
P-9940	RS 485 Network Board, Serial Connection (Class B) 1.2 Km Range	1
P-9940A	RS 485 Network Board, Serial Connection (Class A) 1.2 Km between Panels	1

MANUFACTURED IN ACCORDANCE WITH



Note: Specifications are subject to change without notice.

**GST England** Lion Court, Staunton Harold Hall, Melbourne Road, Ashby de la Zouch, Leicestershire, England LE65 1RT Tel: +44 1283 225 478 Fax: +44 1283 220 690

**GST Dubai** ZA04, Jebel Ali Free Zone, P.O.Box 17998, Dubai UAE  
Tel: +971 (0)4 8833 050 Fax: +971 (0)4 8833 053

**GST China** 80, Changjiang East Road, Economic & Technology Development Zone Qinhuangdao, Hebei, China Tel: +86(0)335 850 2383 Fax: +86 (0)335 850 7588